

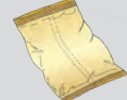

### BAG STYLES:



FLAT-BOTTOM



PILLOW STYLE



EUROSLOT/  
HOLE PUNCH



QUAD-SEAL



GUSSETED



BRICK FOLD-DOWN  
/TAPE-DOWN

### MAXIMUM SPEED:

Up to **100** cycles  
per minute

### MAXIMUM BAG SIZE:

260 mm x 400 mm  
(10.24" x 15.75")

### MINIMUM BAG SIZE:

50 mm x 60 mm  
(1.97" x 2.36")

A RUGGED POWERHOUSE THAT IS FLEXIBLE, FUNCTIONAL, AND ECONOMICAL.



### VIKING MASEK VFFS

E250

E400

ES400

**M250**

M250 BiB

M400

M500

M650

S250

S400

SACHET SA300-SA500

SIGMA

STICK PACK ST200-ST800

VELOCITY

## FEATURES:

- Robust stainless steel frame
- Enclosed, direct drive jaw actuation
- Off-the-shelf components
- Minimal maintenance requirements
- Short film path
- Small machine footprint
- No tool changeover
- Self-centering pull belts
- Automatic film tracking
- VFD powered film unwind
- Quick film splice table
- Product stagers
- End-seal cooling air
- Bag deflators
- Photo eye and encoder
- Tri-fold guard door
- Jaw obstruction detection
- Runs most film structures
- Storage for 100 product recipes

## OPTIONS:

- Quad seal bag assembly
- Flat bottom bag assembly
- Horizontal jaw for up to 340 mm (13.39") wide bag
- Siemens or Allen Bradley control platform
- Impulse sealing for poly film structures
- Integration with variety of fillers, printers, metal detectors, label applicators, and checkweighers
- Washdown construction
- Vacuum pull belts
- Hole punch (Euroslot and Round)
- Load shelf
- Product settler
- Gas flush
- Static eliminator
- Tear notch
- Degassing valve applicator
- In-feed and take-away conveyors
- Remote diagnostics
- Zipper applicator

## M250 VIEWS:

FRONT

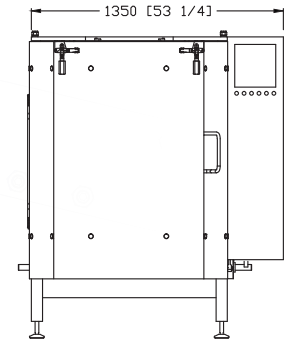

SIDE

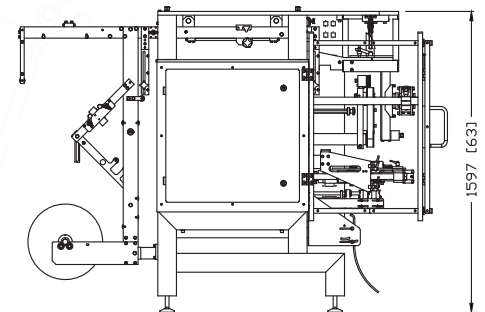

TOP

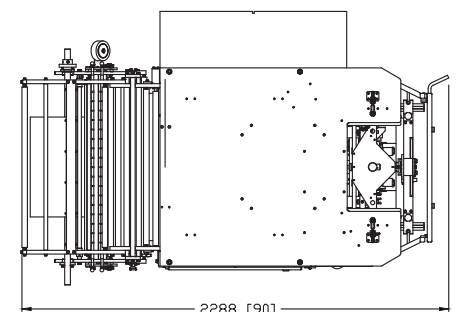

Standard views, dimensions may vary.

